



HC2 Lift stand

Thank you for choosing our DRC "HC2 Lift Stand"

Contents of package

1. Stand body ——— 1pc
2. Kick arm ——— 1pc
3. Arm shaft ——— 2pcs
4. E-Clip ——— 3pcs (1 spare)

Lubricate inside of lifting shaft and stand base's square pole.

ASSEMBLY INSTRUCTIONS

- 1) Install kick arm to stand body with kick arm shafts.
- 2) Shafts are held in position by the E-Clips.

Note

By setting the top plate 5mm lower than your bike's ground clearance, you can lift up your bike with one easy step.

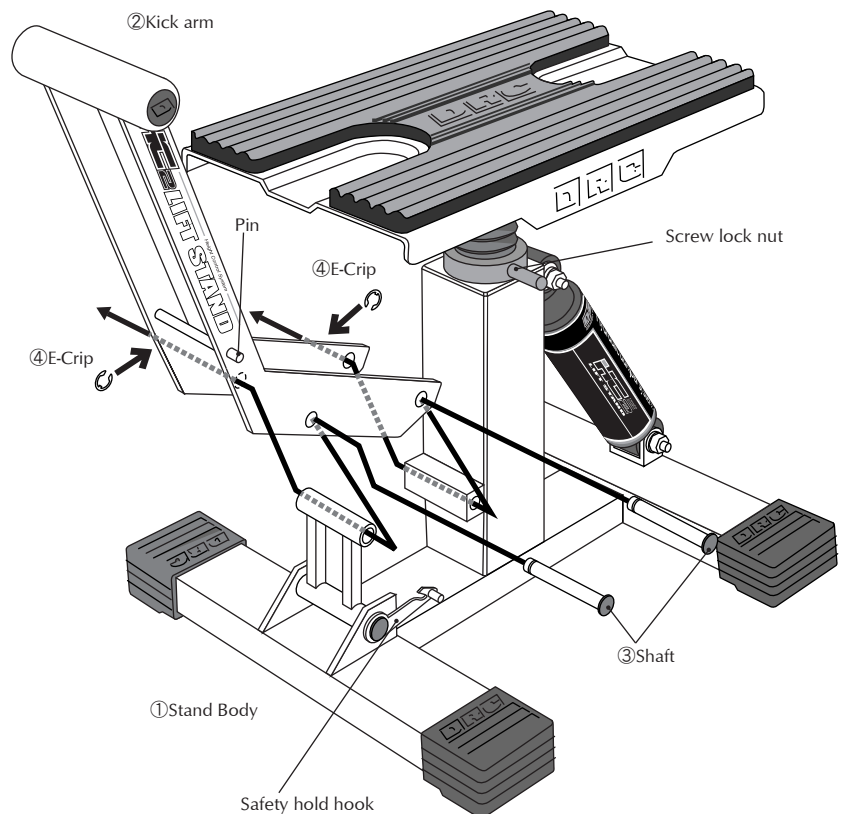

CAUTION

After you set the stand's height, please fasten "Screw lock nut" tightly.
 This Stand's maximum weight capacity is 150kg.
 Don't sit on the bike while it is on the stand.
 The kick arm comes up fast when released. Please be careful that your leg or other body parts do not get caught between the kick arm and top plate or your bike. Please use "Safety Hold Hook" to prevent accidents. The "Safety Hold Hook" installs after your lift up your bike.

How to use "Safety hold hook"

